

ENDA EUXXX SERIES PROGRAMMING DIAGRAM

Entering from the "Programming Mode" to the "Running mode":

If no key is pressed within 20 seconds during "Programming Mode", the data is stored automatically and the "Running mode" is entered.

Alternatively, the same function occurs first pressing key is pressing "Programming Mode" is entered. Then keys

are pressing together, data is recorded and "Running mode" is entered.

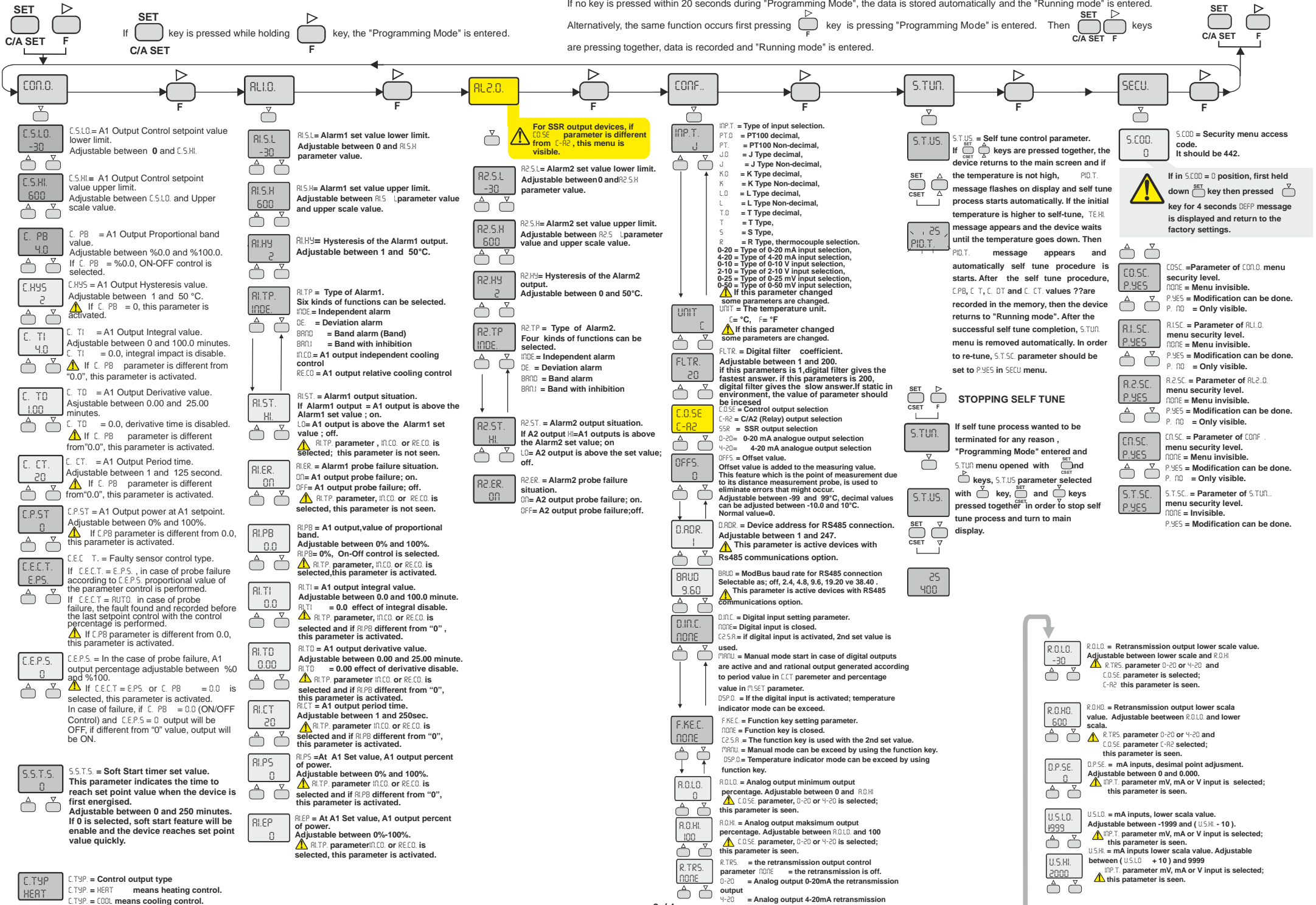

CONNECTION DIAGRAM

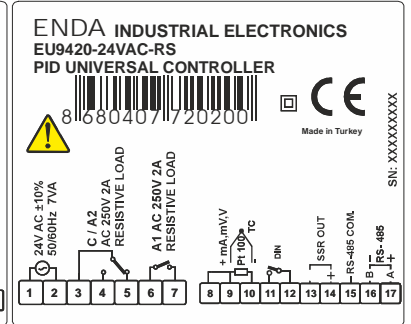
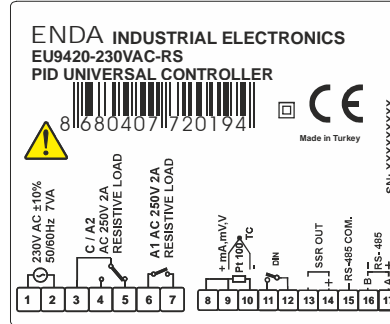
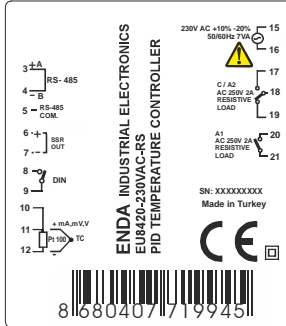
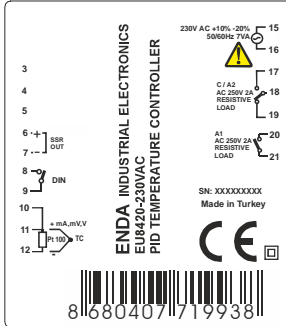
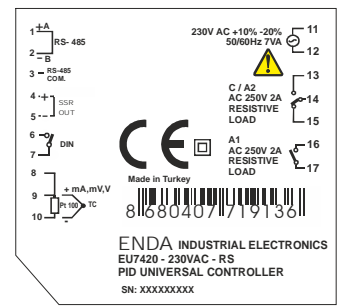
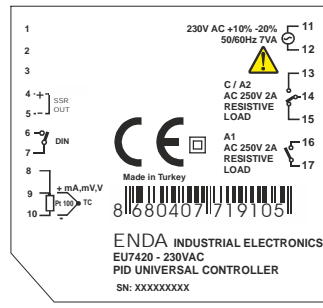
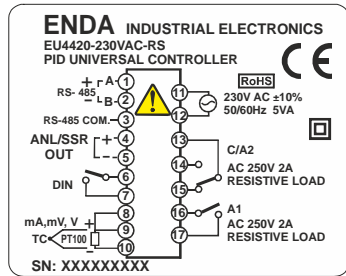
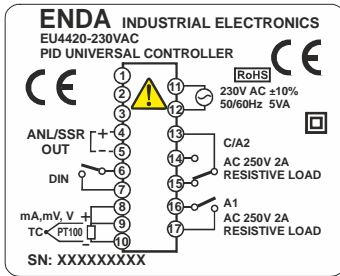

NOTE :

SUPPLY VOLTAGE	Eu4420	Eu7420	Eu8420	Eu9420
184-253V AC 50/60Hz 7VA	9 10	11 12	15 16	1 2

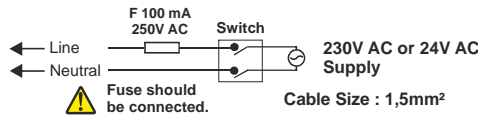

Equipment is protected throughout by DOUBLE INSULATION.

Holding screw 0.4-0.5Nm

SENSOR INPUT:

For J - K - T - S and R Thermocouples :
Use the correct compensating cable.
Do not make any supplement to cables. Connect the thermocouple cables to the right places at the input terminal.

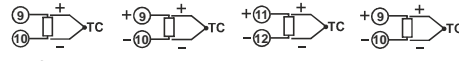

For resistance (PT100) Sensor :
When using 2-wire PT100 sensor, as shown in the figures, make 8 and 9 terminals short circuit for EU4420, EU7420 and EU9420 devices, make 10 and 11 terminals short circuit for EU8420 devices.

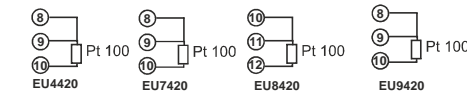

Logic output of the instrument is not electrically insulated from the internal circuits. Therefore, when using a grounding thermocouple, do not connect the logic output terminals to the ground.

Note :

- 1) Mains supply cords shall meet the requirements of IEC 60227 or IEC 60245.
- 2) In accordance with the safety regulations, the power supply switch shall bring the identification of the relevant instrument and it should be easily accessible by the operator.

ALARM1 AND ALARM2 OUTPUT TYPES

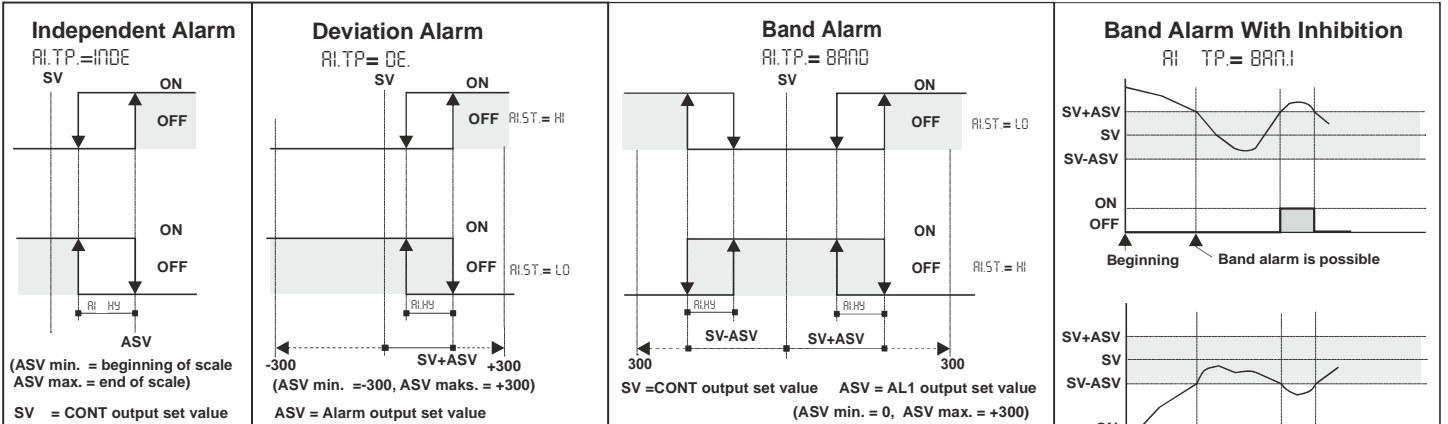

SETTING UP ALARM CONTROL AND SETPOINT VALUES

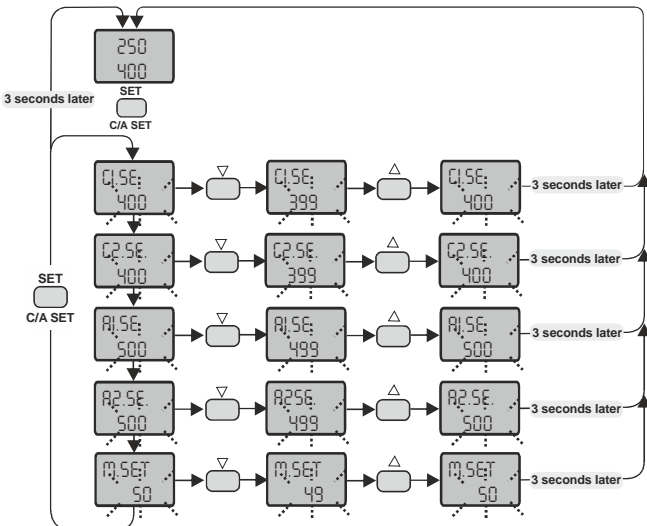

If one of the **D.M.C.** or **F.K.E.C.** parameters are set to the **C2.S.E.** value, this parameter is seen.

If the **C.O.S.E.** parameter is set to SSR out, this parameter is seen.

If one of the **D.M.C.** or **F.K.E.C.** parameters are set to the **M.A.N.U.** value and if **C.P.B.** is different from 0, this parameter is seen.

ERROR MESSAGES

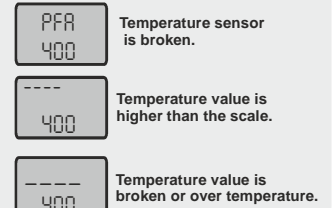

DIMENSIONS

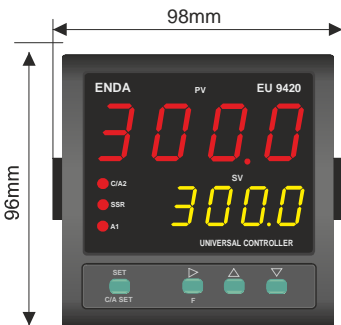
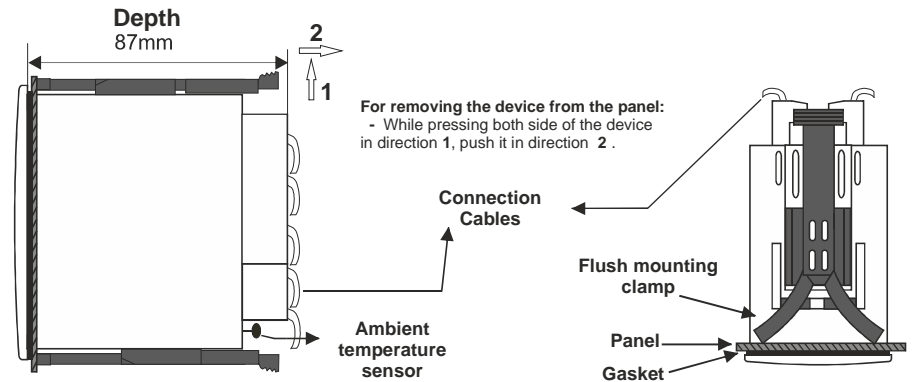
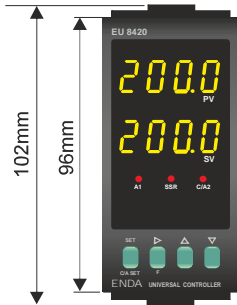
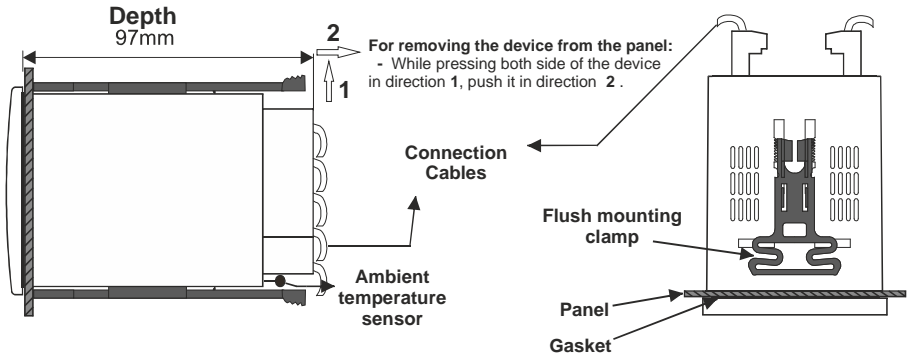
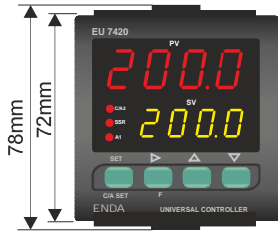
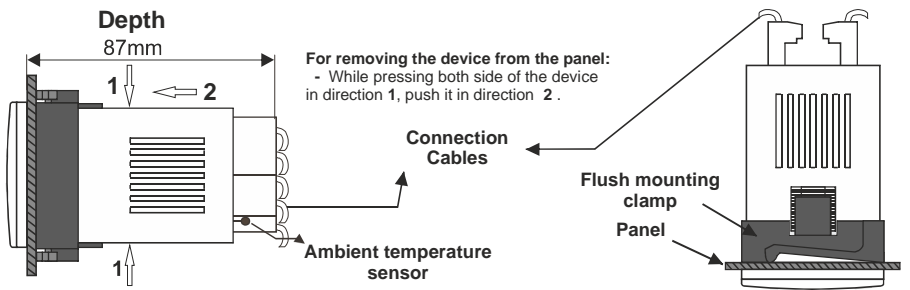
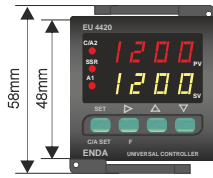

For removing the device from the panel:
- While pressing both side of the device in direction 1, push it in direction 2.

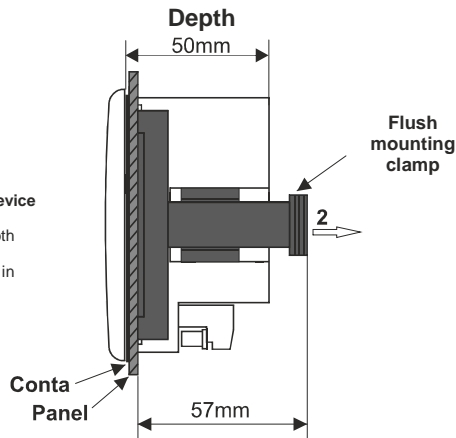

PANEL CUT-OUT

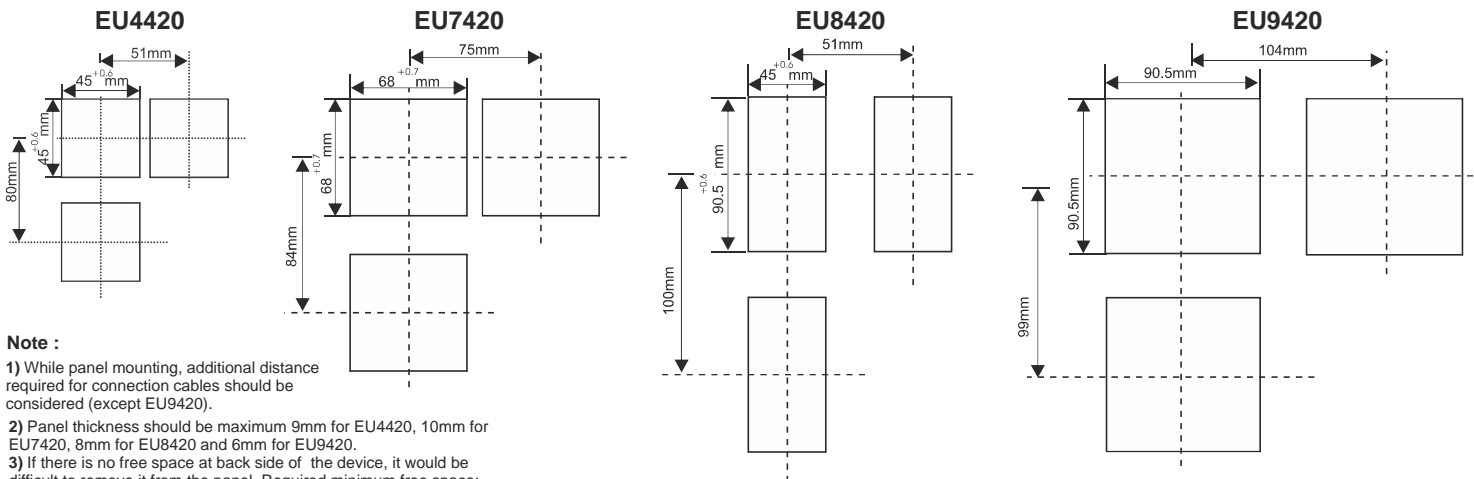

Note :

- 1) While panel mounting, additional distance required for connection cables should be considered (except EU9420).
- 2) Panel thickness should be maximum 9mm for EU4420, 10mm for EU7420, 8mm for EU8420 and 6mm for EU9420.
- 3) If there is no free space at back side of the device, it would be difficult to remove it from the panel. Required minimum free space: EU4420 = 100mm, EU8420 = 90mm, EU9420 = 60mm.

ENDA EUx420 SERIES PID TEMPERATURE CONTROLLER MODBUS PROTOCOL ADDRESS MAP

	Parameter Number	Holding Register Addresses Desimal (Hex)	Data Type	Data Content	Read / Write Permission	Factory Defaults
Control Output Parameters	H0	0000d (0000h)	Word	Control output, temperature setpoint value	Read / Write	400
	H1	0001d (0001h)	Word	Control output, 2nd temperature setpoint value	Read / Write	400
	H2	0002d (0002h)	Word	Control output, minimum setpoint value	Read / Write	0
	H3	0003d (0003h)	Word	Control output, maximum setpoint value	Read / Write	600
	H4	0004d (0004h)	Word	Control output, proportional band setpoint value (Adjustable between %0.0 and %100.0)	Read / Write	4
	H5	0005d (0005h)	Word	Control output, hysteresis value (Adjustable between 1 and 50 °C or °F)	Read / Write	2
	H6	0006d (0006h)	Word	Control output, integral time (Adjustable between 0.1 and 100.0 minute)	Read / Write	40
	H7	0007d (0007h)	Word	Control output, derivative time (Adjustable between 0.01 and 10.00 minute)	Read / Write	100
	H8	0008d (0008h)	Word	Control output, time period setpoint value (Adjustable between 1 and 125 second)	Read / Write	20
	H9	0009d (0009h)	Word	Control output, set value power ratio (Adjustable between %0 and %100)	Read / Write	0
	H10	0010d (000Ah)	Word	Control output, set value power ratio in case of sensor failure (Adjustable between %0 and %100)	Read / Write	0
A1 Output Parameters	H11	0011d (000Bh)	Word	Control output, soft start value	Read / Write	0
	H12	0012d (000Ch)	Word	Alarm1 output temperature setpoint value	Read / Write	500
	H13	0013d (000Dh)	Word	Alarm1 output minimum setpoint value limit	Read / Write	0
	H14	0014d (000Eh)	Word	Alarm1 output maximum setpoint value limit	Read / Write	600
	H15	0015d (000Fh)	Word	Alarm1 output proportional band set value (Adjustable between %0.0 and %100.0)	Read / Write	0
	H16	0016d (0010h)	Word	Alarm1 output hysteresis value (Adjustable between 1 and 50 °C or °F)	Read / Write	2
	H17	0017d (0011h)	Word	Alarm1 output, integral time (Adjustable between 0.1 and 100.0 minute)	Read / Write	0
	H18	0018d (0012h)	Word	Alarm1 output, derivative time (Adjustable between 0.01 and 10.00 minute)	Read / Write	0
	H19	0019d (0013h)	Word	Alarm1 output, time period setpoint value (Adjustable between 1 and 125 second)	Read / Write	20
	H20	0020d (0014h)	Word	Alarm1 output, set value power ratio (Adjustable between %0 and %100)	Read / Write	0
	H21	0021d (0015h)	Word	Alarm1 output, set value power ratio in case of sensor failure (Adjustable between %0 and %100)	Read / Write	0
A2 Output Parameters	H22	0022d (0016h)	Word	Alarm1 output type selection (Values can be given from 0 to 4) (0 = Independent alarm, 1 = Deviation alarm, 2 = Band alarm, 3 = Active alarm after in band time, 4 = Alarm1 output, cooling control selection)	Read / Write	0
	H23	0023d (0017h)	Word	Alarm2 output, temperature setpoint value	Read / Write	500
	H24	0024d (0018h)	Word	Alarm2 output minimum setpoint value limit	Read / Write	0
	H25	0025d (0019h)	Word	Alarm2 output maximum setpoint value limit	Read / Write	600
	H26	0026d (001Ah)	Word	Alarm2 output, hysteresis value (Adjustable between 1 and 50 °C or °F)	Read / Write	2
Configuration Parameters	H27	0027d (001Bh)	Word	Alarm2 output type selection (Values can be given from 0 to 3) (0 = Independent alarm, 1 = Deviation alarm, 2 = Band alarm, 3 = Active alarm after in band time)	Read / Write	0
	H28	0028d (001Ch)	Word	Input selection number (0 = PT100 Decimal, 1 = Pt100 Non-decimal, 2 = J Decimal, 3 = J Non-decimal, 4 = K Decimal, 5 = K Non-decimal, 6 = L Decimal, 7 = L Non-decimal, 8 = T Decimal, 9 = T Non-decimal, 10= S Non-decimal, 11 = R Non-decimal.	Read / Write	5
	H29	0029d (001Dh)	Word	ModBus device address (Adjustable between 1 and 247)	Read / Write	1
	H30	0030d (001Eh)	Word	Modbus communication speed (Baudrate) (0 = Modbus cancel, 1 = 2400 bps, 2 = 4800 bps, 3 = 9600 bps, 4 =19200 bps, 5 = 38400 bps)	Read / Write	3
	H31	0031d (001Fh)	Word	Digital filter coefficient (Adjustable between 1 and 200, 1 = filter is disable)		10
	H32	0032d (0020h)	Word	Control output, selection value (0 = C/A2 Control output selection, 1 = SSR Output) ATTENTION !! H42 parameter will be 0 if this parameter set to different from 0.		0
	H33	0033d (0021h)	Word	Analog output minimum out percentage		0
	H34	0034d (0022h)	Word	Analog output maximum out percentage	Read / Write	100
	H35	0035d (0023h)	Word	Offset value	Read / Write	0
	H36	0036d (0024h)	Word	Function control parameter. (23040d (5A00h) self tune stops when this value is entered) (23041d (5A01h) self tune starts when this value is entered) (23042d (5A02h) returns to factory defaults when this value is entered)	Read / Write	0
	H37	0037d (0025h)	Word	Reserved	Read / Write	XX
	H38	0038d (0026h)	Word	Reserved	Read / Write	XX
	H39	0039d (0027h)	Word	Manual control output percentage (Adjustable between %0 and %100)	Read / Write	50

ENDA EUx420 SERIES PID TEMPERATURE CONTROLLER MODBUS PROTOCOL ADDRESS MAP

1.1 Memory Map for Holding Registers (continue)

	Parameter Number	Holding Register Addresses Desimal (Hex)	Data Type	Data Content	Read / Write Permission	Factory Defaults
	Configuration Parameters	H40	0040d (0028h)	Word	Digital input control parameter (0 = Digital input off, 1 = 2nd set value is selected with digital input, 2 = Manual mode is entered via digital input, 3 = Digital input is passed to display mode	Read / Write
H41		0041d (0029h)	Word	Function key control parameter (0 = Function key off, 1 = 2nd Set value is selected with function key, 2 = Manual mode is entered via function key, 3 = With the function key display mode is entered)	Read / Write	0
H42		0042d (002Ah)	Word	Retransmission output control parameter: If this parameter is 0 , Retransmission output; off If this parameter is 1 , Analog output; 0-20mA Retransmission output If this parameter is 2 , Analog output; 4-20mA Retransmission output ATTENTION!! To setting up this parameter, H32 parameter must be set to 0.	Okunabilir / Yazilabilir	0
H43		0043d (002Bh)	Word	Retransmission output lower scala value.	Okunabilir / Yazilabilir	0
H44		0044d (002Ch)	Word	Retransmission output upper scala value.	Okunabilir / Yazilabilir	600
H45		0045d (002Dh)	Word	Decimal point adjustment for mA and V input	Okunabilir / Yazilabilir	0
H46		0046d (002Eh)	Word	Users upper scale value for 2-20mA, 4-20mA, 0-10V and 2-10V amper input selecting	Okunabilir / Yazilabilir	0
H47		0047d (002Fh)	Word	Users lower scale value for 2-20mA, 4-20mA, 0-10V and 2-10V amper input selecting	Okunabilir / Yazilabilir	9999
H48		0048d (0030h)	Word	Control output menu, security parameter (0 = Menu invisible, 1 = Menu programmable, 2 = Menu only visible)	Read / Write	1
H49		0049d (0031h)	Word	Alarm1 output menu security parameter (0 = Menu invisible, 1 = Menu programmable, 2 = Menu only visible)	Read / Write	1
H50		0050d (0032h)	Word	Alarm2 output menu, security parameter (0 = Menu invisible, 1 = Menu programmable, 2 = Menu only visible)	Read / Write	1
H51		0051d (0033h)	Word	Configuration menu, security parameter (0 = Menu invisible, 1 = Menu programmable, 2 = Menu only visible)	Read / Write	1
H52		0052d (0034h)	Word	Self tune menu, security parameter (0 = Menu invisible, 1 = Self tune can be done)	Read / Write	1

1.2 Memory Map for Coils

Parameter Number	Coil Addresses	Data Type	Data Content	Read / Write Permission	Factory Defaults
C0	(0000)h	Bit	Alarm2 Status (0 = Active Low ,1 =Active High)	Read / Write	1
C1	(0001)h	Bit	Alarm2 output position in case of Prob failure (0 = Off , 1 = On)	Read / Write	0
C2	(0002)h	Bit	Alarm1 Status (0 = Active Low ,1 =Active High)	Read / Write	1
C3	(0003)h	Bit	Alarm1 output position in case of Prob failure (0 = Off , 1 = On)	Read / Write	0
C4	(0004)h	Bit	Control output configuration (0 = Heat ; 1 = Cool)	Read / Write	0
C5	(0005)h	Bit	Temperature unit (0 = °C ; 1 = °F)	Read / Write	0
C6	(0006)h	Bit	Control outputs active (0 = Control outputs active, 1 = Only display mode)	Read / Write	0
C7	(0007)h	Bit	Controlling according to 2nd temperature setpoint (If C7 = 0 is H0, if C7 = 1 is H1)	Read / Write	0
C8	(0008)h	Bit	Auto/Manual selection (0 = Automatic "Running mode", 1 = Manual "Running mode". In this mode, output generated according to H39 parameter.)	Read / Write	0
C9	(0009)h	Bit	Control format in case of probe failure (0 = H10 proportional control according to percentage value, 1 = Error found before the setpoint control is done with the value of the proportional control)	Read / Write	0

1.3 Memory Map for Input Registers

Parameter Number	Input Register Addresses Desimal (Hex)	Data Type	Data Content	Read / Write Permission
I0	0000d (0000h)	Word	Measured temperature	Read Only
I1	0001d (0001h)	Word	Percentage of analog output	Read Only
I2	0002d (0002h)	Word	Measurement error codes 0 = No error, 1 = Sensor disconnected or broken, 2 = Lower scale error, 3 = Upper scale error, 4 = PT100 short circuit or temperature too low, 5 = Wrong input selection	Read Only
I3	0003d (0003h)	Word	Self tune condition codes 0 = No error, 1 = Initial temperature is higher than 60% setpoint value, 2 = Calculating PID parameters, 3 = Calculating power set parameters	Read Only
I4	0004d (0004h)	Word	Current (active) temperature setpoint.	Read Only
I5	0005d (0005h)	Word	Reserved	Read Only
I6	0006d (0006h)	Word	Current (active) decimal point value (0 = No decimal point, 1 = 0.0 Decimal point is tenths)	Read Only

1.4 Memory Map for Software Revision Input Registers

Software Revision	61472d (F020h)	14 Word	<p>Software name and update is read in ASCII format and as 14 word. Sample : EU4420-01 22 AUG. 2016.</p> <p>Memory Formats :</p> <p>Word Word Word Word Word Word Word Word Word Word Word Word Word Word Word Word</p> <p>1 2 3 4 5 6 7 8 9 10 11 12 13 14</p> <p>E U 4 4 2 0 - 0 1 2 2 A U G . 2 0 1 6</p> <p>NOTE : To view each word correctly by changing the byte sequences should be displayed as ASCII TEXT</p>	Read Only
-------------------	----------------	---------	---	-----------

ENDA EUx420 SERIES PID TEMPERATURE CONTROLLER MODBUS PROTOCOL ADDRESS MAP

1.5 Memory Map for Discrete input

Parameter Numarasi	Discrete Input Addresses	Data Type	Data Content	Read / Write Permission
D0	(0000)h	Bit	C/A2 Control output status (0 = OFF ,1 = ON)	Read Only
D1	(0001)h	Bit	A1 Output status (0 = OFF , 1 = ON)	Read Only
D2	(0002)h	Bit	SSR Output status (0 = OFF ,1 = ON)	Read Only
D3	(0003)h	Bit	Digital input status (0 = OFF ,1 = ON)	Read Only

2. MODBUS ERROR MESSAGES

Modbus protocol has two types error, communication error and operating error. Reason of the communication error is data corruption in transmission. Parity and CRC control should be done to prevent communication error. Receiver side checks parity and CRC of the data. If they are wrong, the message will be ignored. If format of the data is true but function doesn't perform for any reason, operating error occurs. Slave realizes error and sends error message. Most significant bit of function is changed '1' to indicate error in error message by slave. Error code is sent in data section. Master realizes error type via this message.

ModBus Error Codes

Error Code	Name	Meaning
01	ILLEGAL FUNCTION	The function code received in the query is not an allowable action for the slave. If a Poll Program Complete command was issued, this code indicates that no program function preceded it.
02	ILLEGAL DATA ADDRESS	The data address received in the query is not an allowable address for the slave.
03	ILLEGAL DATA VALUE	A value contained in the query data field is not an allowable value for the slave.

Message example;

Structure of command message (Byte Format)

Device Address		(0A)h
Function Code		(01)h
Beginning address of coils.	MSB	(04)h
	LSB	(A1)h
Number of coils (N)	MSB	(00)h
	LSB	(01)h
CRC DATA	LSB	(AC)h
	MSB	(63)h

Structure of response message (Byte Format)

Device Address		(0A)h
Function Code		(81)h
Error Code		(02)h
CRC DATA	LSB	(B0)h
	MSB	(53)h

As you see in command message, coil information of (4A1)h = 1185 is required but there isn't any coil with 1185 address. Therefore error code with number (02) (Illegal Data Address) sends.

